

BILL OF MATERIAL

MARK	QTY	DESCRIPTION	LENGTH	WEIGHT	REMARKS
G1	1	GATE			BEV-2
G1	1	L3X3X1/4	5'-10"	29	A36
a2	1	L3X3X1/4	5'-10"	29	A36
a3	2	L3X3X1/4	7'-7 1/2"	75	A36
m1	1	1.5B_22GA	BOI	77	B.O.I.
m2	1	1.5B_22GA	BOI	72	B.O.I.
m7	1	RING	BOI	0	B.O.I.
m10	2	PIPE3/4SCH40	0'-3"	1	A53
m11	1	PIPE3/4SCH40	0'-2"	0	A53
p3	1	PL1/2"X1/2"	0'-8"	1	A36
pl2	1	PL1/4"X1 1/2"	9'-6 1/2"	12	A36
r1	1	RB3/4"	1'-10 5/16"	3	A36
r2	1	STUD1/2"	0'-1 1/2"	0	A108
TOTAL WEIGHT THIS DRAWING				297	

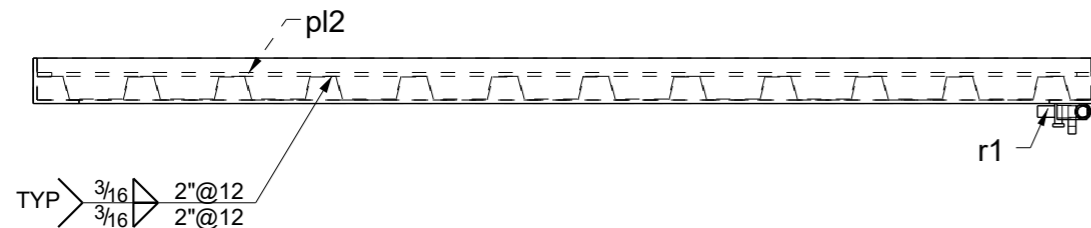

B - B

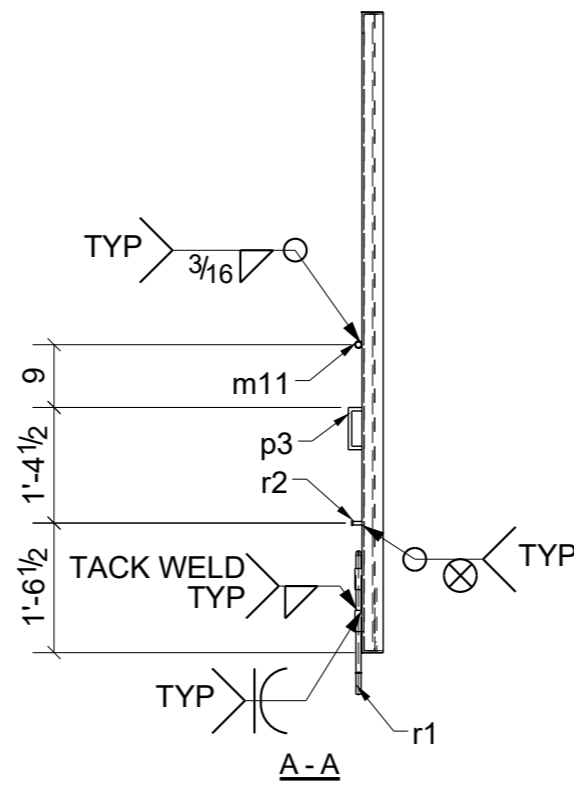
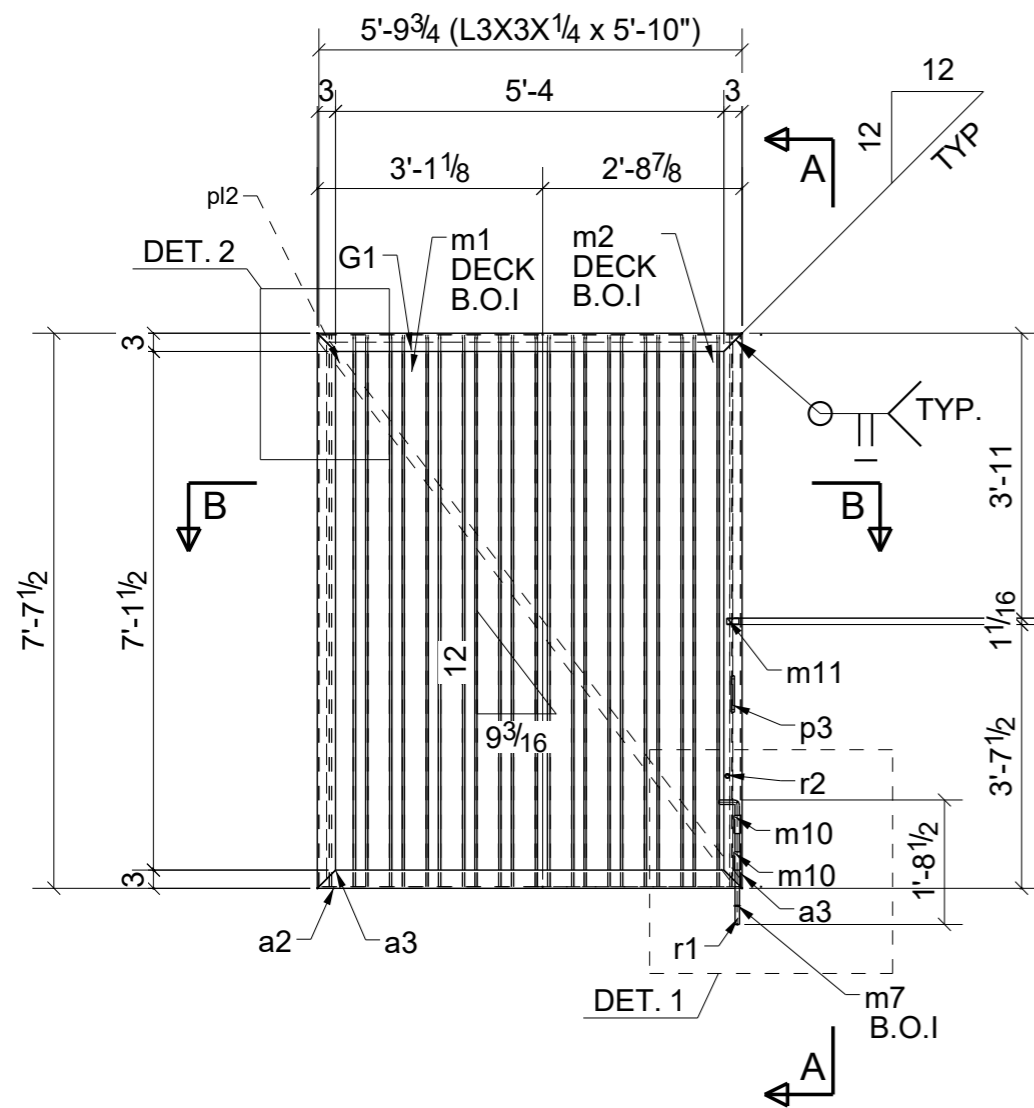

For Quality Control Box

CUT: _____

FAB: _____

CECK: _____

WELD: _____

PRE PAINT: _____

QC: _____

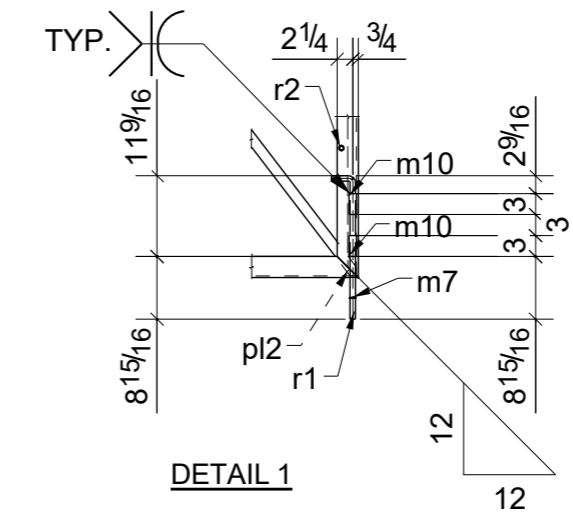

DETAIL 1

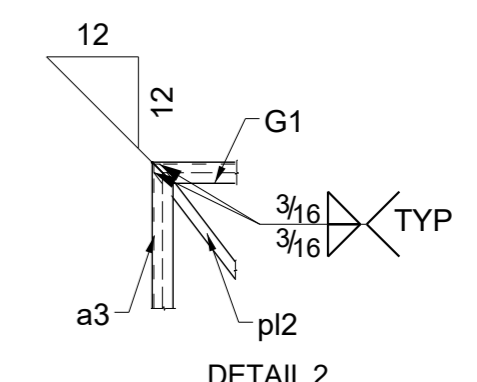

DETAIL 2

ONE - GATE - G1