

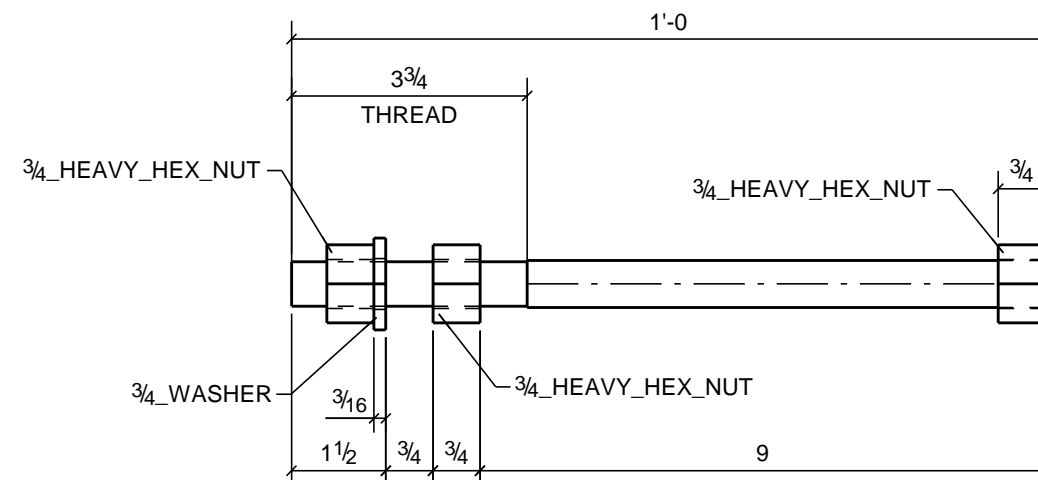

MATERIAL LIST

NOTES:	MARK	#PCS.	MATERIAL	LENGTH	WEIGHT
SQ-2	AB100	72	ANCHOR RODS		
Red Oxide Prime F1554-36	AB100	72	ROD 3/4"	1'-0"	94
		216	3/4_HEAVY_HEX_NUT		40
		72	3/4_WASHER		5
TOTAL WEIGHT THIS DRAWING					94



72 - ANCHOR RODS - AB100

SIoux CITY FOUNDRY CO.
 801 DIVISION STREET SIoux CITY, IA. 51102
 712-252-4181 800-831-0874
 (FAX) 712-252-4197
 YOUR FULL SERVICE STEEL COMPANY
 www.siouxcityfoundry.com



PROJECT: South Dakota State Universi	CONTRACTOR: Clark Drew Construct									
SHOP NOTES: 1. MATERIAL: A36 U/NOTED 2. HOLES: 13/16 U/NOTED 3. ALL HOLES NOTED S.C. MUST BE DEBURRED, OTHERWISE BURRS OF 1/16 OR LESS ARE ALLOWED 4. ELECTRODES: E70XX 5. ALL GAS RE-ENTRANT COPIES OR CUTS ARE TO HAVE A MINIMUM RADIUS 6. SURFACE PREP: SSPC-SP6 U/NOTED 7. PAINT: Red Oxide Primer 8. DRY MIL TH'K 2 1/2 MILS U/NOTED 9. PAINT OPEN HOLES U/NOTED S.C. 10. TOLERANCES: AISC U/NOTED 11. ALL BOLTED CONNECTIONS A325N U/NOTED 12. ALL SHOP BOLTS SHALL BE TIGHTENED WITH A WRENCH, BUT NOT TORQUED	Revisions: <table border="1" style="width: 100%; border-collapse: collapse;"> <thead> <tr> <th>Description</th> <th>Date:</th> </tr> </thead> <tbody> <tr> <td>0 For Fabrication</td> <td>02/13/19</td> </tr> <tr> <td>B For Re-Approval</td> <td>12/04/18</td> </tr> <tr> <td>A For Approval</td> <td>11/30/18</td> </tr> </tbody> </table>	Description	Date:	0 For Fabrication	02/13/19	B For Re-Approval	12/04/18	A For Approval	11/30/18	DRAWN BY: SSH DATE: 11/30/2018 CHECKED BY: AMT DATE: 12/04/2018 S.O. 1238874 SHEET NO. AB100 REV. 0
	Description	Date:								
	0 For Fabrication	02/13/19								
	B For Re-Approval	12/04/18								
	A For Approval	11/30/18								
	FIELD BOLTS:									

Tekla structures